



## PERFORMANCE DATA SHEET

**Meets or exceeds MEPS (Minimum Efficiency Performance Standards), as described by the US Department of Energy in docket 10CFR431 and Natural Resources Canada's Amendment 14**

Catalogue #: MTR-104FDCH

HP	kW	Voltage	Frequency	EFF.	P.F.	Frame	Design	F.L. RPM
1	0,75	115 / 208 - 230	60Hz	79,8%	0,909	56C	B	1760

FLA			Service Factor	N.L. Amps @ 115V	N.L. Amps @ 230V	KVA Code	L.R. Amps @ 15v	L.R. Amps @ 230v
115	208	230		1,15	3,85		1,927	K
9,09	5,02	4,54						

Start Cap.	Run Cap.	Main Winding $\Omega$ 115V @ 25°C	Main Winding $\Omega$ 230V @ 25°C	Auxillary Winding $\Omega$ @ 25°C	Safe Cold Start (Secs)
250 $\mu$ f/300vac	50 $\mu$ f/450vac	0,5000	1,990	2,250	12

Wgt. Lbs	PH	Duty	Insul. Class	Amb.	Elevation	Temp. Rise° C
38	1	Cont.	F	40°C	1000M (3,300 Ft)	63

% Efficiency		Power Factor		Torque		Protection
Full Load:	79,8%	Full Load:	0,91	Full Load Ft/Lbs	3,0	
3/4 Load:	69,1%	3/4 Load:	0,88	Locked Rotor %	302	
1/2 Load:	51,1%	1/2 Load:	0,86	Break Down %	312	

Rotor Inertia Wk2 Lb-Ft2	Max Load Inertia Wk2 Lb-Ft2	Shaft Material	Frame Material	DE Bracket Type	ODE Bracket Type	Enclosure	NEMA Rating	Lead Wire Size
/	/	Steel	Rolled Steel	Aluminium Alloy		TEFC	IP55	/

Ball Bearings		Grease	Mount Type	Orientation	Paint	Sound Pressure @ 3FT	Sound Power
DE	ODE						
6205	6203	Sealed Bearings	Rigid	Horizontal	Grey	68	/

### WIRING CONNECTION DIAGRAM : A

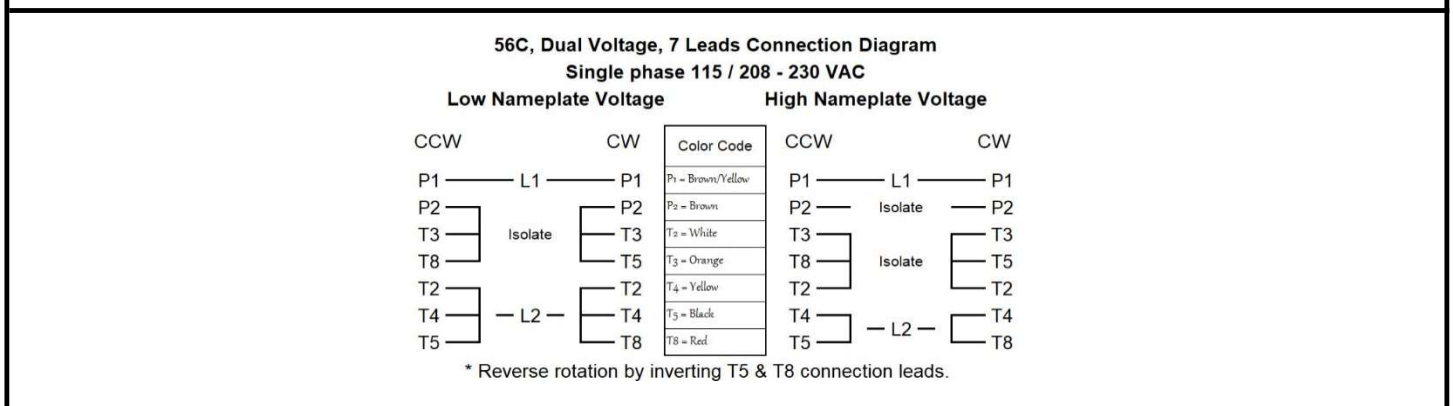



Date: 2023-12-22  
 Customer: \_\_\_\_\_  
 Contact: \_\_\_\_\_  
 Submittee: J.C. Lavallée

Catalogue #: **MTR-104FDCH**

**Meets or exceeds MEPS (Minimum Efficiency Performance Standards), as described by the US Department of Energy in docket 10CFR431 and Natural Resources Canada's Amendment 14**

HP	VAC	RPM	Enclosure	Frame	Frequency	Design	Poles	LR Code Letter	Insulation Class	Temp. Rise °C
1	230	1760	TEFC	56C	60	B	4	K	F	63

Load %	0%	25%	50%	75%	100%	125%	150%
Amps	3,22	3,45	3,68	4,00	4,54	5,68	6,81
Torq ft/lbs	0	0,73	1,48	2,23	2,98	3,75	4,53
RPM	0	1790	1780	1770	1760	1750	1740
Eff	0	29,38	51,11	69,06	79,80	80,20	82,73
PF	0,00	80,00	86,17	88,17	90,90	89,08	86,36

	Locked Rotor	Pull-Up	Breakdown	Rated Load	Idle	Duty	S. F.	Ambient	Elevation	dBa @ 1M
Speed (RPM)	0	900	1440	1760	1800	Continuous	1,15	40°C	3,300 ft	68
Current (Amps)	32	27,2	19,0	4,54	3,2234	VFD Rating: Meets MG1 parts 31.4.4.2				
Torque (ft-lbs)	9,01	7,66	9,31	2,98	0,0	C.T.	1,99	V.T.	2,25	

